

XPLORER 4K

User Manual

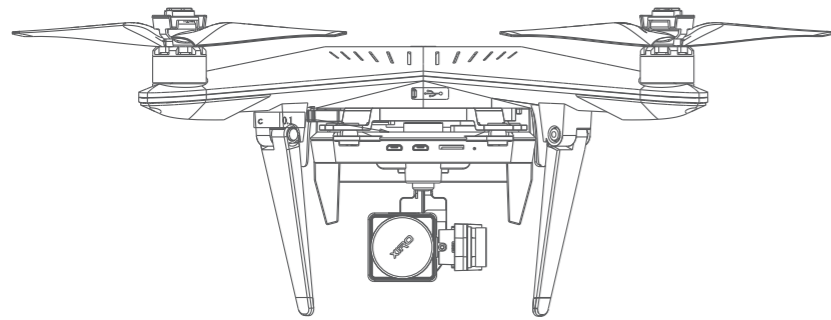

XIRO

- XIRO Customer Support Mainland China: <as-cn@xirodroner.com>
- XIRO Service Center Hong Kong: <as-hk@xirodroner.com>
- XIRO Service Center Taiwan: <as-asia@xirodroner.com>
- XIRO Service Center North America: <as-usa@xirodroner.com>
- XIRO Service Center Europe: <as-europe@xirodroner.com>
- XIRO Customer Support Asia: <as-asia@xirodroner.com>
- XIRO Service Center Oceania: <as-au@xirodroner.com>
- XIRO Service Center Other Area: <as@xirodroner.com>

1. Video Tutorials

- Watch the XIRO video tutorials before your first flight and make sure you feel safe to fly the Xplorer. You can scan the QR code to watch the video tutorials or find the videos on <http://www.xirodrone.com/support>.



2. Download XIRO app

- Scan the QR code below to download and install the latest version of the XIRO App.



- The XIRO app can be installed in IOS 8.0 and above or Android 4.4 and above.

3. Checking/Charging battery capacity

Checking the remaining battery capacity

Press the green button on the battery to check the remaining battery capacity.

- Four green LED light: 75%-100%
- Three green LED light: 50%-75%
- Two green LED light: 25%-50%
- One green LED light: 0%-25%

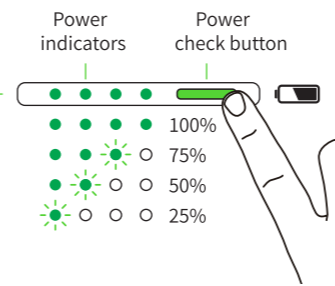
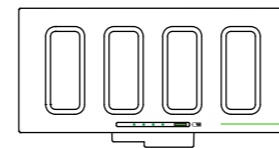

Checking the remaining remote control capacity

Power on the remote control, the current power level of the remote control will be shown.

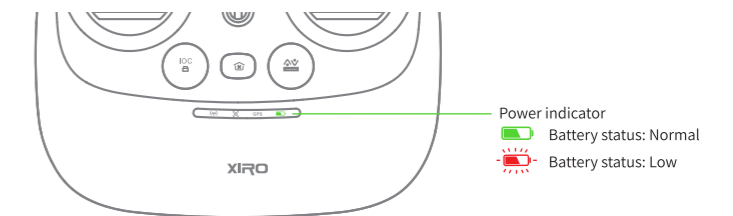

Charging

- ⚠ Charge the smart flight battery and remote control after opening the packaging.

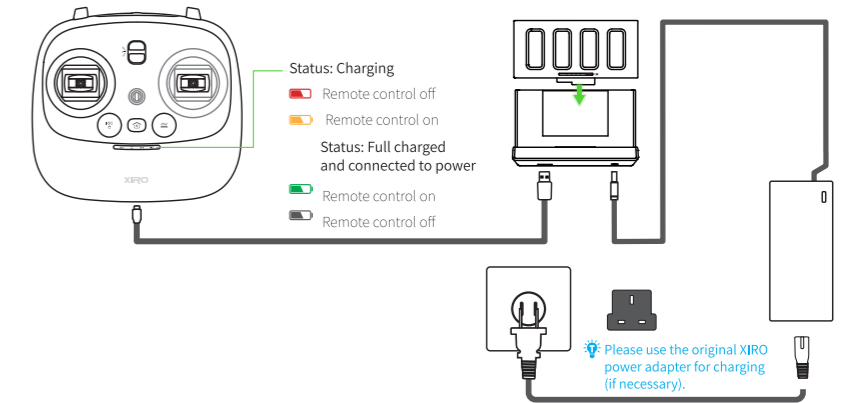

- ⚠ Voltage range/frequency: 100-240V AC, 50/60Hz
- Please use the original XIRO power adaptor for charging.

1

2

5. Xplorer Assembly

Installing the smart flight battery

Step1 Turn your Xplorer on its back on a flat surface. Pair the connector of the battery with the pin slot.

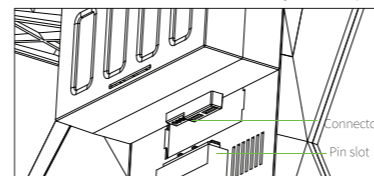

Step2 Check that the battery is inserted fully flat to the bottom of the Xplorer.

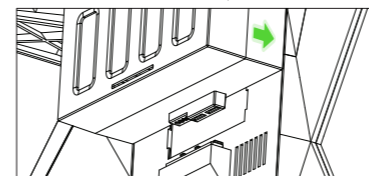

Step3 Push the battery towards the direction of the green arrow until it is locked.

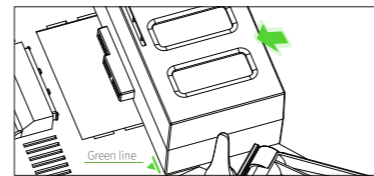

Step4 Push down the battery lock. The battery is locked when the lock is at level with the green line.

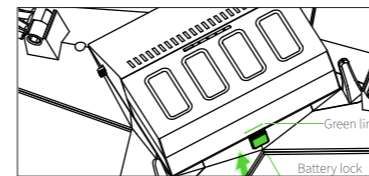

- ⚠ Make sure the smart flight battery is firmly installed, fully flat to the bottom. Otherwise it may become detached during flight and causing the Xplorer to crash. A crash caused by a not correctly installed battery is not covered by our product warranty.

Mounting the propellers

Step1 Mount the silver propellers on the silver motors and the black propellers on the black motors.

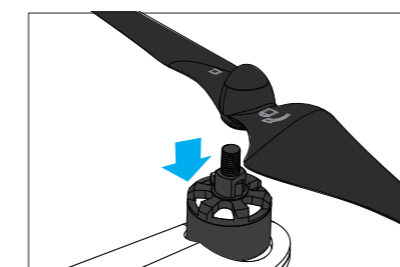
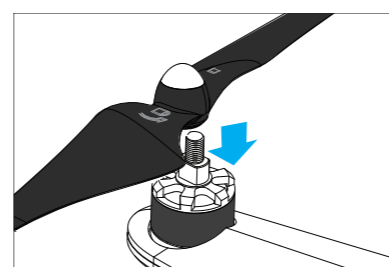

Step2 Tighten the silver propellers by spinning counter-clockwise and tighten the black propellers by spinning clockwise.

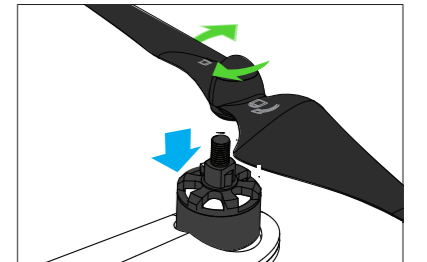
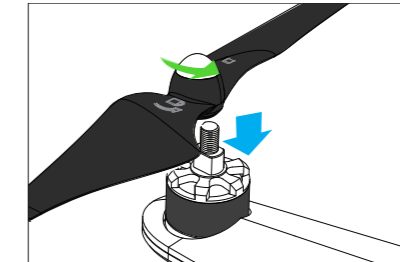

Note:

1. Check if the propellers are mounted correctly and firmly. They are self tightening during flight.
2. Do not use damaged or broken propellers.
3. Keep a safe distance and do not touch propellers or motors while spinning.
4. Use original XIRO propellers for a safe and relaxed flight experience.
5. The edges of the propellers can become sharp, be careful when installing and removing the propellers.

Installing Wi-Fi range extender

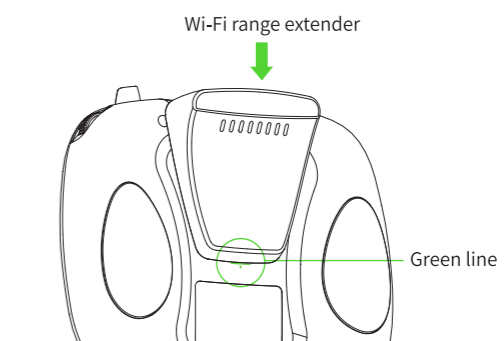

- Step 1 Turn off the remote control.
- Step 2 Align the range extender with the green line on the back of your remote control.
- Step 3 Push the range extender downwards until it is fixed.
- Step 4 Power on the remote control. When the Wi-Fi connection indicator turns red the range extender is installed successfully.

- ⚠ If you have any questions, we ask you to check our support pages on <http://xirodroner.com/support>. Here you will find our latest FAQ, Video tutorials and the contact details for our regional XIRO Service Centers.

3

4

